

Adaptable Magnetic Shape Memory Alloy Pump for Lab-on-Chip Applications

Tim Polley

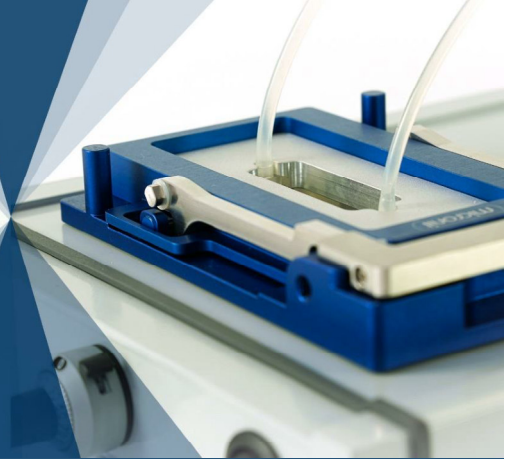

HNP Mikrosysteme GmbH • Bleicherufer 25 • 19053 Schwerin • T +49 385 52190-300 • info@hnp-mikrosysteme.de • www.hnp-mikrosysteme.de

HNP Mikrosysteme GmbH
2023



Products

- Micro annular gear pumps
- Industrial microfluidics
- Dispensing technology
- Systemized solutions

Company

- Start 1998 in Parchim
- Turnover 18 Mio. EUR in 2022
- Employees 92



HNP Mikrosysteme GmbH
Bleicherufer 25
19053 Schwerin (Germany)

phone +49 385 52190-300
fax +49 385 52190-333
e-mail info@hnp-mikrosysteme.de
URL http://www.hnp-mikrosysteme.de

- **efficient** micro fluidic handling
- **accuracy** and reliability
- **precise** and **continuous** volume flow in $\mu\text{l}/\text{min}$ range
- **low costs** and high quantities
- **interaction** of **complex materials**, such as plastics, adhesives, and other materials affects functionality of microfluidic systems

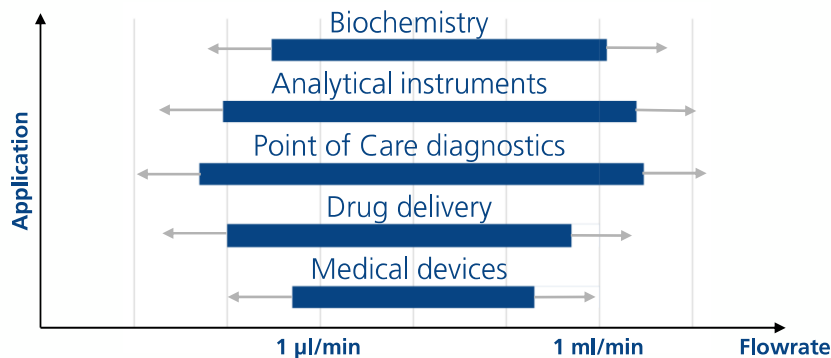

Operating principle – linear peristaltic volume flow magnetic shape memory (msm) pump

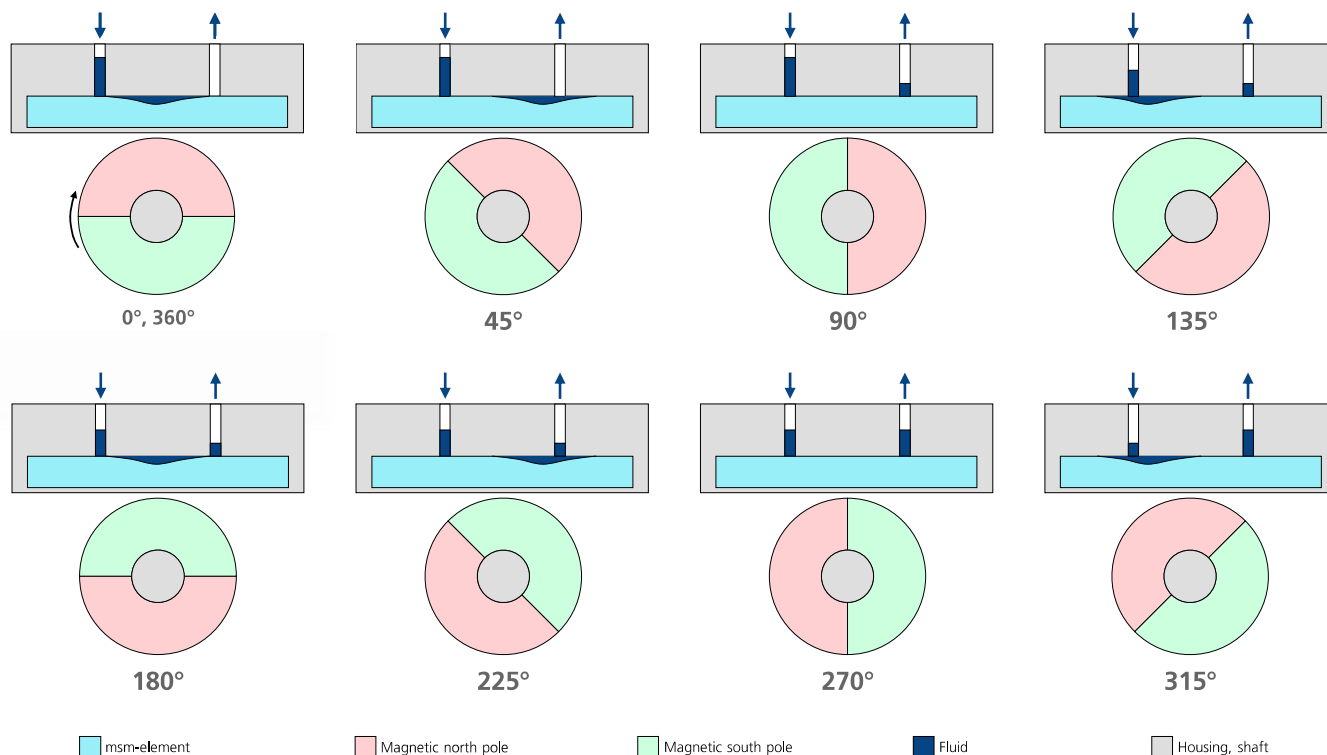

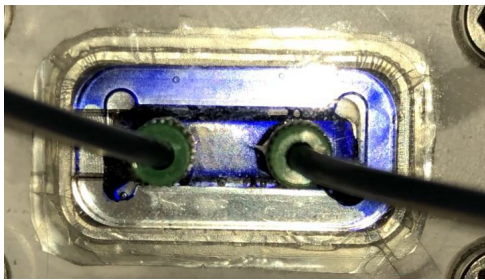
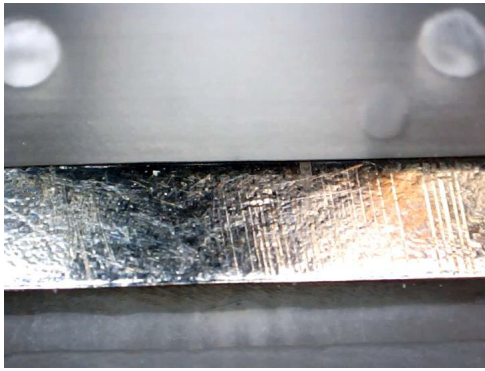

Material – NiMnGa

magnetic shape memory alloy

- Magnetically actuated single-crystal metal alloy of **nickel, manganese and gallium**
- Folding of tetragonal martensitic structure causes volume-constant **strain** in the longitudinal direction while tapering in the transverse direction
- Maximum strain **6 %**
- Perpendicular magnetic field **strains** the element, parallel magnetic field **contracts** the element



Source: ETO Magnetic

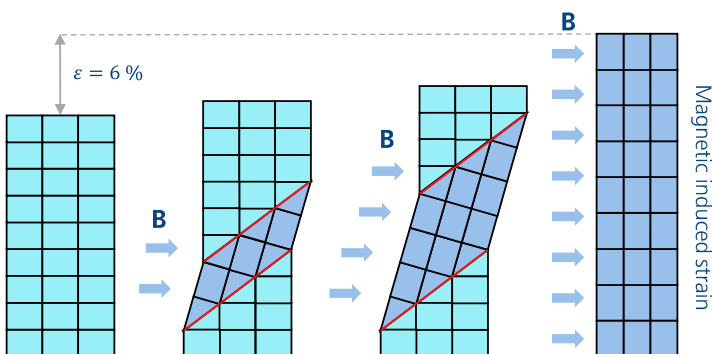

Alloy	Ni ₂ MnGa
Temperature limits	-40 to +60°C
Strain	6 % at 2 N/mm ²
Lifetime	500 million load cycles
Frequency	1 kHz

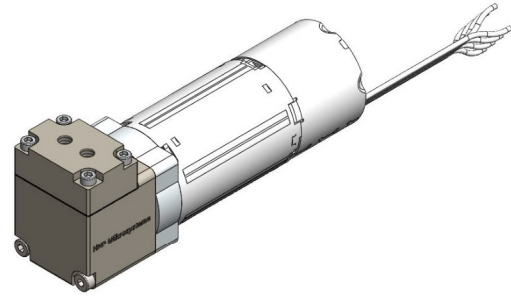
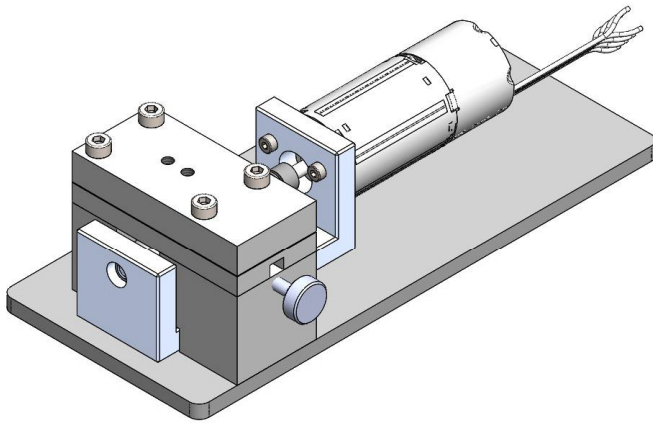

- Completed research project
- Proof-of-Concept
- Functional prototypes

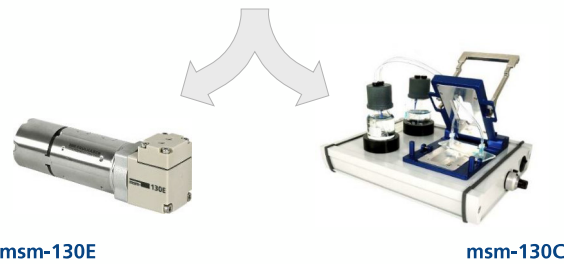

msm-130E

msm-130C

msm-pump characteristics

Characteristics

- Flow rate **10 nl/min** to **2 ml/min**
- Internal volume **8,5 µl**
- Differential pressure **500 mbar** (5 bar expected by simulation)
- Lifetime msm-element up to **2,5 a**



msm-130E

Advantages

- Minimum circulation volume
- Liquid-separated fluid delivery
- Combined pump and valve function
- Low-cost pump (positive displacement principle)
- Self-priming and bidirectional volume flow
- Separable pump and drive unit



msm-130C

Pump design »single sided planar msm-pump«

Design and specification msm-130E

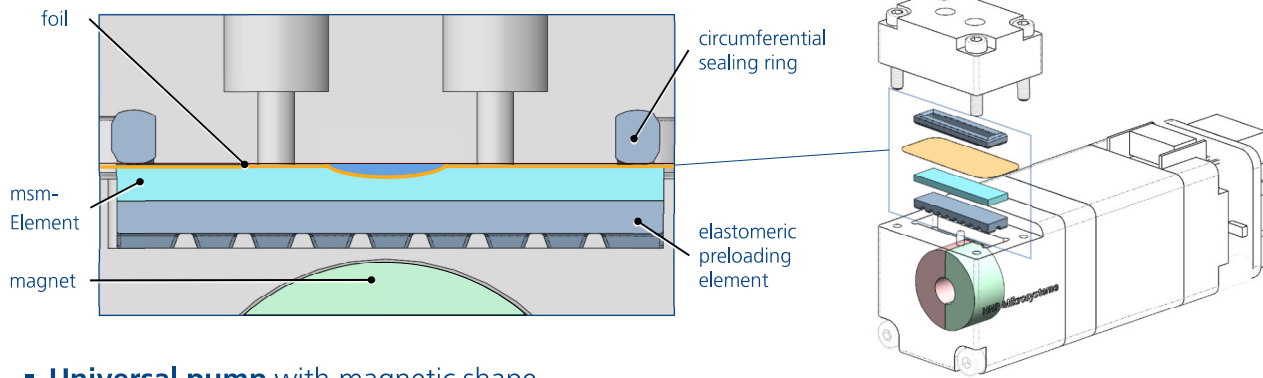

- **Universal pump** with magnetic shape memory (msm) element
- Separable pump and drive unit
- **Disposable pump head** with fluid cover, circumferential sealing ring and foil for media separation
- **Reusable drive unit with** msmelement, elastomeric preloading element and rotating magnet

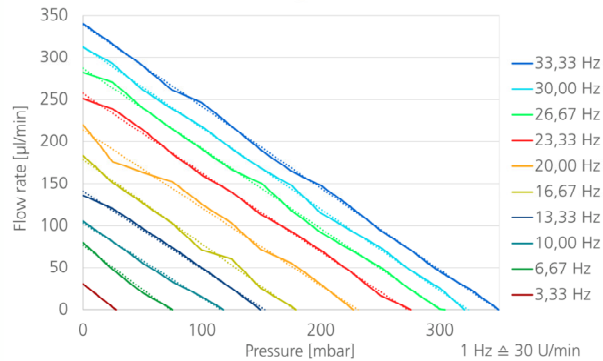

Pump design »Lab-on-chip msm-pump«

Design and specification msm-130C

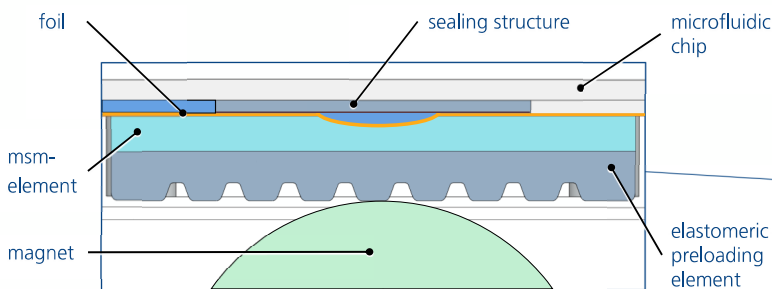

- **Lab-on-chip** pump with msmelement
- Separable fluidic chip and drive unit
- **Disposable fluidic chip** with foil-based sealing structure for media separation
- **Reusable drive and clamping unit** for the fluidic chip with msmelement, elastomeric preloading element and rotating magnet

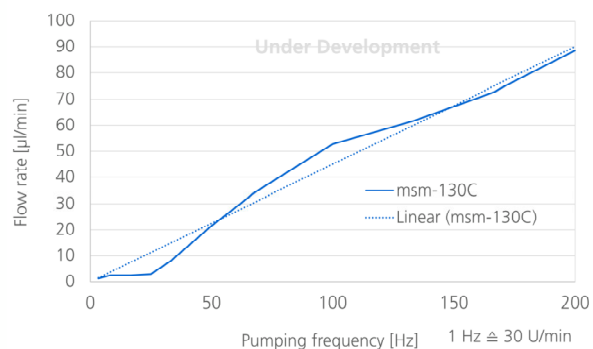
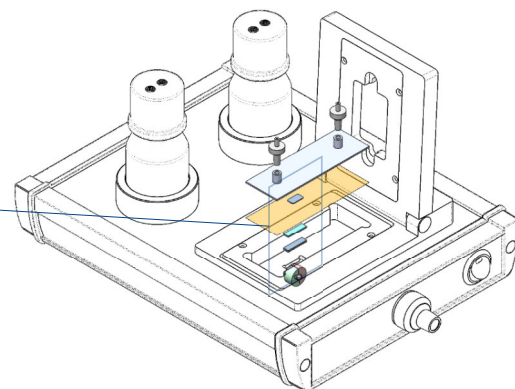

Adaptable msm-pump

Requirements and advantages for Lab-on-Chip

Requirements

- Active area on the chip requires an elastic membrane
- Elastic membrane is able to follow the moving cavity
- Adhesive layer between msm-element and elastic membrane

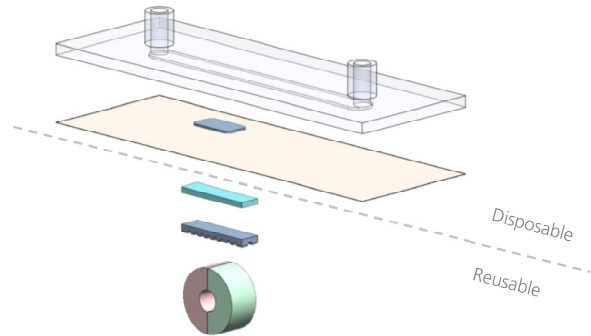
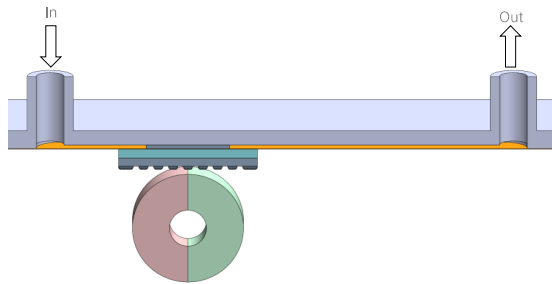

Advantages

- Interface between msm-element and microfluidic chip
- No fluid connections - close setup and minimum circulation volume
- Easy handling and fast chip exchange

Applications

magnetic shape memory pump

msm-130E



msm-130C



Infusion pump



Source: www.medicalexpo.de, Coslan Argus a707708v

Insulin pump



Source: www.omnipod.com

Source: Medtronic GmbH

Lab-on-chip pump

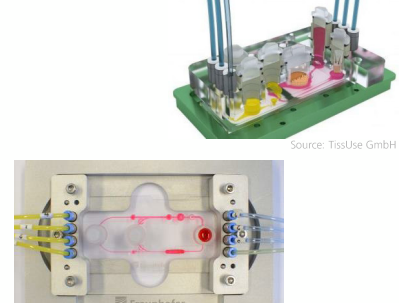

Source: TissUse GmbH

Source: Fraunhofer IWS

Characteristics

Flow rate	max. 2500 µl/min	0,200 µl/min	dispense volume: 0,5 µl	≤ 100 µl/min
Differential pressure	100 – 1000 mbar	100 – 1000 mbar		≤ 350 mbar
Lifetime msm-element (related to flow rate)	500 million load cycles (867 h)	500 million load cycles (10.833 h / 1,24 a)	500 million load cycles (742 a at 480 dosages per day)	500 million load cycles (21.667 h / 2,48 a)

Project status

magnetic shape memory pump technology

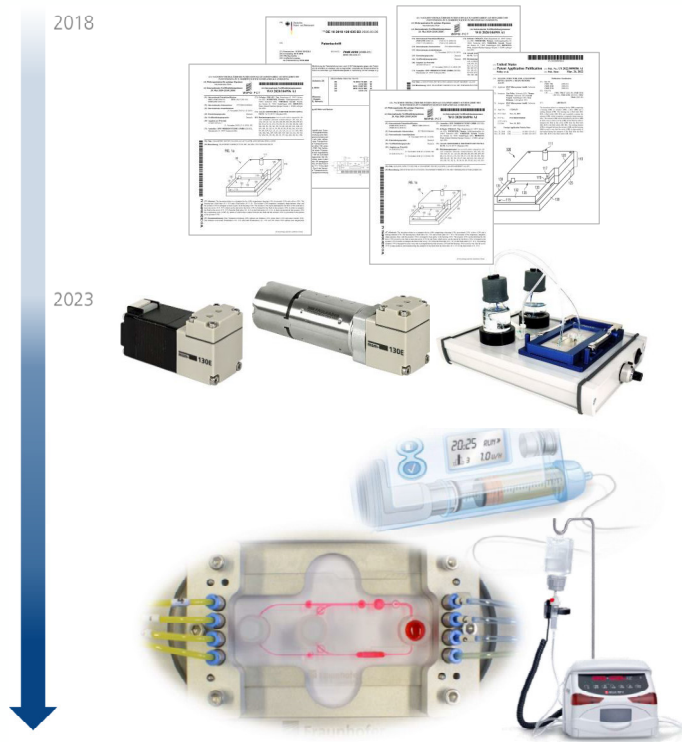

Phase 1

- Proof-of-concept
- prototypes **msm-130C** and **msm-130E**
- Patent applications HNPM

Phase 2

- **application-related** further development
 - Lab-on-chip pump
 - Infusion pump
 - Insulin pump
- Deepen **technology maturity**

Phase 3

- Launch

Thank you for your attention

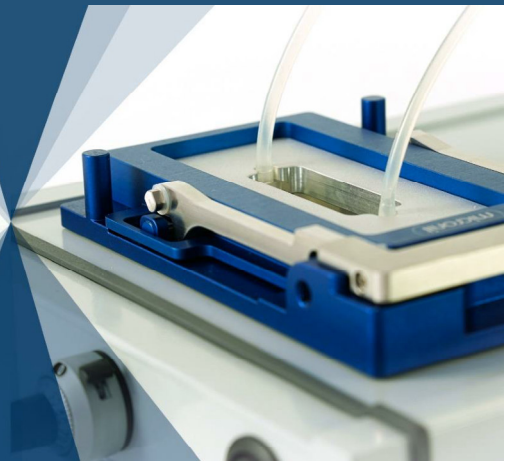

HNP Mikrosysteme GmbH
Bleicherufer 25
19053 Schwerin (Germany)

www.hnp-mikrosysteme.de

Tim Polley

tim.polley@hnp-mikrosysteme.de
+49 385 52 190 367